

**U.S. DEPARTMENT OF AGRICULTURE
FOREST SERVICE**

SPECIFICATION

SHOVEL, FOREST FIRE

1. SCOPE

1.1 Scope. This specification covers a solid shank style shovel used in wildland fire fighting.

2. APPLICABLE DOCUMENTS

2.1 Government documents. The following government documents, of the issue in effect on date of the solicitation or request for proposal, form a part of this specification to the extent specified herein.

2.1.1 Government specifications and standards.

STANDARDS

FEDERAL

FED-STD-123 - Marking for Shipment (Civil Agencies)

FED-STD-376 - Preferred Metric Units for General Use by the Federal Government

(Unless otherwise indicated, copies of federal standards are available from the Standardization Documents Order Desk, Building 4D, 700 Robbins Ave., Philadelphia, PA 19111-5094.)

2.1.2 Other Government documents, drawings, and publications. The following form a part of this document to the extent specified herein.

DRAWINGS

USDA FOREST SERVICE

MTDC-1050 - Shovel, Forest Fire

(Copies are available from USDA Forest Service, Missoula Technology and Development Center, 5785 Highway 10 West, Missoula, MT 59808.)

Beneficial comments (recommendations, additions, deletions) and any pertinent data that may be used in improving this document should be addressed to: USDA Forest Service, Missoula Technology and Development Center, 5785 Highway 10 West, Missoula, MT 59808 by using the Specification Comment Sheet at the end of this document or by letter.

5100-326D

2.2 Non-Government publications. The following documents form a part of this document to the extent specified herein. Unless otherwise specified, the issues of these documents are those in effect on the date of the solicitation or request for proposals.

AMERICAN NATIONAL STANDARDS INSTITUTE (ANSI)

B46.1 - Surface Texture (Surface Roughness, Waviness, and Lay)

(Address requests for copies to American National Standards Institute, Inc., 1430 Broadway, New York, NY 10018.)

AMERICAN SOCIETY FOR QUALITY (ASQ)

Z1.4 - Sampling Procedures and Tables for Inspection by Attributes

(Copies are available from the American Society for Quality, 611 East Wisconsin Avenue, Milwaukee, WI 53202.)

ASTM International (ASTM)

D 3951 - Standard Practice for Commercial Packaging
D 5118 - Standard Practice for Fabrication of Fiberboard Shipping Boxes
E 18 - Standard Test Methods for Rockwell Hardness and Rockwell Superficial Hardness of Metallic Materials

(Copies are available from ASTM, 100 Barr Harbor Dr., West Conshohocken, PA 19428-2959.)

AMERICAN WELDING SOCIETY

A2.4 - Standards for Welding and Non-Destructive Testing

(Address requests for copies to American Welding Society, P.O. Box 351040, Miami, FL 33135.)

IRON AND STEEL SOCIETY

Alloy, Carbon and High Strength Steel, Semifinished for Forging, Hot Rolled Bars; Cold Finished Steel Bars; Hot Rolled Deformation and Plain Concrete and Reinforced Bar

(Address requests for copies to Iron and Steel Society, 410 Commonwealth Dr., Warrendale, PA 15086.)

NATIONAL MOTOR FREIGHT TRAFFIC ASSOCIATION, INC., AGENT

National Motor Freight Classification

(Copies are available from American Trucking Associations, Inc., 2200 Mill Rd., Alexandria, VA 22314.)

(Non-Government standards and other publications normally are available from the organizations that prepare and distribute the documents. These documents also may be available in or through libraries or other informational services.)

2.3 Order of precedence. In the event of conflict between the text of this document and the references cited herein, the text of this document takes precedence. Nothing in this document, however, shall supersede applicable laws and regulations unless a specific exemption has been obtained.

3. REQUIREMENTS

3.1 First article. Unless otherwise specified (see 6.2), a sample shall be subjected to first article inspection (see 6.3) in accordance with 4.3. During the term of the contract the contractor shall be required to notify the contracting officer in writing when a component, or the component supplier, changes in any way; when a major manufacturing process changes in any way; and when a manufacturing location changes. The contracting officer may at any time require the contractor to submit a new first article sample when substantive changes occur during the term of the contract.

3.2 Materials and construction. The shovel covered by this specification shall conform in all respects to the design, details, dimensions, and materials specified herein and in the referenced drawing, MTDC-1050. Should there be conflicts between the text of this document and the drawing, this document takes precedence.

3.2.1 Blade and socket. The blade and socket shall conform to the configuration and dimensions shown in MTDC-1050. The socket shall be either tab end or square top pattern.

3.2.1.1 Blade style. The design of the shovel blade shall be the solid shank style. The solid shank style shall be roll forged and formed from one solid steel bar making blade and shank integral. The shank and the center or thickest portion of the blade at the shoulder end shall be formed to provide a frog. The blade shoulders shall be turned to form non-cutting, forward-turned steps.

3.2.1.2 Steel composition. The blade shall be made from special quality, hot top, fully killed, fine grain carbon AISI/SAE 1060,1050 or 5150 steel (UNS G10600, G10500 or G5150). Steel composition of the blade shall be determined as specified in 4.5.1.1.

3.2.1.3 Steel hardness. The full length of the blade and four inches of the socket, measured from the blade shoulder, shall be hardened to a value of not less than 38 nor more than 47 on the Rockwell C scale. Steel hardness shall be determined in accordance with 4.5.1.2.

3.2.1.4 Blade thickness. Blade thickness shall be 0.069 minimum inch measured in the three areas shown in MTDC-1050.

3.2.1.5 Finish of cutting edge. The cutting edge of the shovel blade as shown in MTDC-1050 shall be beveled to an angle of 35 degrees minimum and 50 degrees maximum to the adjacent back surface. The finished blade shall have a sharpened cutting edge. The cutting edge shall be ground to a finish having a roughness of not more than 125 microinches as defined by ANSI B46.1.

5100-326D

3.2.2 Handle. The handle shall be ash, which includes wood cut from white ash (*Fraxinus americana*), green ash (*Fraxinus pennsylvanica*), and blue ash (*Fraxinus quadrangulata*). Permitted colors are white, light red, and light brown, with dark red and dark brown permitted within 10 inches of either end. The wood shall show between 5 and 17 annual rings per inch of radius. The maximum permitted cross grain shall be 1/2 diameter in the bottom 2/3, 1/2 diameter in the top 1/3, and 2/3 diameter in the top 7 inches. The blemishes shall not exceed 1 slight dip in grain, or 2 pin twig marks, small streaks, or butterfly marks per handle. The wood shall show between 5 and 17 annual rings per inch of radius. The maximum permitted cross grain shall be 1/2 diameter in the bottom 2/3, 1/2 diameter in the top 1/3, and 2/3 diameter in the top 7 inches. The blemishes shall not exceed 1 slight dip in grain, or 2 pin twig marks, small streaks, or butterfly marks per handle. Dimensions shall conform in all respects to drawing MTDC-1050. The handle shall be free from crooks, bows, cracks, splits, and scores.

3.2.2.1 Handle finish. The handle shall be sanded to a smooth finish and coated with a minimum of one coat of clear water base lacquer. No wax or stain is allowed. The lacquer shall be applied evenly over the surface and shall be free of sags, runs, blisters, drips, wrinkles, frothing, or other nonconformities characteristic of improper application or cure. If the dip method is used, coating of the tapered end of the handle is optional. Flame hardening is optional.

3.2.2.2 Moisture content. Moisture content of the handle at the time of assembly shall not exceed 12 percent when tested as specified in 4.5.2.1.

3.2.3 Sheath. The plastic sheath used to package each tool (see 5.2) shall be NSN 8465-01-136-4719, and shall be acquired from the National Institute for the Severely Handicapped (NISH) Development Workshop, Inc, 555 West 25th Street, Idaho Falls, ID 83402 (phone #208-524-1550). The pricing shall not exceed that posted on the internet at www.JWOD.com.

3.2.4 Tool assembly. The handle shall fit smoothly and tightly into the socket. The handle shall be secured by two rivets located as shown in MTDC-1050. The edges of the socket shall be closed to within 3/16 inch or less and may be welded.

3.2.4.1 Handle rivets. The two rivets affixing the handle to the socket of the blade shall be steel with a $7/32 \pm 1/32$ inch diameter. Rivet heads shall be round top or flat top with chamfered edges. They shall be tight and flush to contact surfaces.

3.2.5 Tool weight. Weight of the assembled shovel shall be 3 pounds, 8 ounces minimum.

3.2.6 Strength. The shovel assembly shall show no evidence of fracture, breaks, splits, nor take on a permanent set exceeding 1 inch when tested in accordance with 4.5.2.2.

3.2.7 Overall length. The complete shovel, with sheath in place, shall fit within a box 51-1/2 inches in inside length.

3.3 Identification marking. Each shovel head shall be marked in a permanently legible manner as follows:

- a. The Federal Supply System ("FSS") mark shall be metal stamped in 1/4 to 1/2 inch-high letters on the inside right corner of the blade, as shown on MTDC-1050, or on the shank at the option of the manufacturer.
- b. The manufacturer's name or trademark shall be metal stamped on the inside right corner of the blade or on the shank, at the option of the manufacturer.

3.4 Workmanship. The finished tool shall be free of rust and all other nonconformities that may affect serviceability, durability, and appearance. The tool shall conform to the quality of product established by this specification. It shall be manufactured using the best commercial workmanship in all respects.

3.5 Metric products. Products manufactured to metric dimensions will be considered on an equal basis with those manufactured using inch-pound units, provided they fall within the tolerances specified using conversion tables contained in the latest revision of FED-STD-376, and all other requirements of this specification are met.

4. QUALITY ASSURANCE PROVISIONS

4.1 Responsibility for inspection. Unless otherwise specified in the contract or purchase order, the contractor is responsible for the performance of all inspection requirements (examinations and tests) as specified herein. Except as otherwise specified in the contract or purchase order, the contractor may use his/her own or any other facilities suitable for the performance of the inspection requirements specified herein, unless disapproved by the Government. The Government reserves the right to perform any of the inspections set forth in this specification where such inspections are deemed necessary to ensure supplies and services conform to prescribed requirements.

4.1.1 Responsibility for compliance. All items shall meet all requirements of sections 3 and 5. The inspection set forth in this specification shall become a part of the contractor's overall inspection system or quality program. The absence of any inspection requirements in the specification shall not relieve the contractor of the responsibility of ensuring that all products or supplies submitted to the Government for acceptance comply with all requirements of the contract. Sampling inspection, as part of manufacturing operations, is an acceptable practice to ascertain conformance to requirements, however, this does not authorize submission of known nonconforming material, either indicated or actual, nor does it commit the Government to accept nonconforming material.

4.1.2 Responsibility for dimensional requirements. Unless otherwise specified in the contract or purchase order, the contractor is responsible for ensuring that all specified dimensions have been met. When dimensions cannot be examined on the end item, inspection shall be made at any point or at all points in the manufacturing process necessary to ensure compliance with all dimensional requirements.

5100-326D

4.1.3 Certification of compliance. Unless otherwise specified, certificates of compliance supplied by the manufacturer of the item, component, or material, listing the specified test method and test results obtained, may be furnished in lieu of actual lot by lot testing performed by the contractor (see 4.3.2). When certificates of compliance are submitted, the Government reserves the right to check test such items to determine the validity of the certification.

4.2 Sampling for inspections and tests. Sampling for inspections and tests shall be made in accordance with ANSI/ASQC Z1.4. The inspection level and acceptable quality level (AQL) shall be as specified. All shovels manufactured at one time shall be considered a lot for purposes of acceptance inspection and test. A sample unit shall be one complete shovel.

4.3 Quality conformance inspection. Each end item lot shall be sampled and inspected as specified in 4.3.4.1 and 4.3.4.2. Each lot shall be sampled and tested as specified by 4.5.2. Test reports showing compliance with 4.5.2.1 and 4.5.2.2 (or 4.5.2.2.1) shall be submitted as part of quality conformance inspections. The packaging shall be sampled as specified in 4.4. Unless otherwise specified (see 6.2), first articles submitted in accordance with 3.1 shall be inspected as specified in 4.3.4.1 and 4.3.4.2. As part of quality conformance inspections, data analysis shall be submitted to determine compliance of the steel composition as specified in 4.5.1.1 and steel hardness as specified in 4.5.1.2. See also 4.5.1.3. Packaging and packing is not part of the first article inspection. The presence of any nonconformities or failure to pass any test shall be cause for rejection of the first article.

4.3.1 Component and material inspection. In accordance with 4.1, components and materials shall be inspected in accordance with all the requirements of referenced documents, drawings, and standards unless otherwise excluded, amended, modified, or qualified in this specification or applicable purchase document.

4.3.2 Certification. Unless otherwise specified (see 6.2), as part of first article presentations and lot inspections, it shall be acceptable for the contractor to provide certificates of compliance for all materials and components in lieu of actual lot by lot testing. In addition, when the contractor changes component or material suppliers, a new certification based on actual test results shall be required. All certificates shall include as a minimum:

- Specification, type, class, form, etc. as applicable
- Quantity purchased
- Purchase source, address, and telephone number
- Purchase date
- Lot number traceable to materials used in production
- Contract number

4.3.3 In-process inspection. Inspection shall be made at any point or during any phase of the manufacturing process to determine whether cut lengths, cut parts, markings for location of components, and location of assembled component parts are in accordance with specified requirements. Whenever nonconformance is noted, corrections shall be made to the parts affected and lot in process. Components that cannot be corrected shall be removed from production.

5100-326D

4.3.4 End item examination.

4.3.4.1 End item visual examination. The end items shall be examined for the nonconformities list in table I on a lot by lot basis. The lot size shall be expressed in units of complete shovels. The inspection level shall be S-3, and the acceptable quality level (AQL), expressed in terms of nonconformities per hundred units, shall be 4.0 for major nonconformities and 15.0 for combined major and minor nonconformities. Unless otherwise specified, nonconformities shall be scored on an individual basis.

TABLE I. End item visual nonconformities

Classification	Nonconformities	Major	Minor	
Examine	Blade and socket			
	Metal not as specified	X		
	Cutting edge not correct angle or not finished as specified	X		
	Cutting edge not beveled as specified	X		
	Radii or contours not faired or smoothly finished	X		
	Broken or skip in weld on back plate	X		
	Edges of rivet heads not flush (exposed sharp edges) with contact surfaces	X		
	Missing or loose rivets	X		
	Handle	Wood not as specified	X	
		Handle broken, cracked, showing crooks or bows, split or scored	X	
Fit in socket not tight and smooth		X		
Markings: "FSS" and mfg. mark	Finish not smooth, has blisters, drips, wrinkles, frothing, etc.	X		
	Wax or stain used	X		
	Omitted, incorrect, illegible, misplaced, or size of characters not as specified		X	

4.3.4.2 End item dimensional examination. End items shall be examined for the nonconformities listed in table II on a lot by lot basis. Only those dimensions that can be evaluated without damaging or disassembling the end items shall be examined. The inspection level shall be S-3. An AQL, expressed in terms of nonconformities per hundred units, shall be 6.5.

TABLE II. End item dimensional nonconformities

Examine	Nonconformities
Blade and socket	Not within dimensions specified by MTDC 1050
	Cutting edge bevel not as specified
Handle	Length not as specified
	Diameters not as specified

5100-326D

4.4 Packaging inspection. An examination shall be made to determine that packing and marking comply with the section 5 requirements. Nonconformities shall be scored in accordance with the list below. The sample unit shall be one shipping container fully packaged except that it shall not be palletized and it need not be closed. Shipping containers fully packaged that have not been palletized shall be examined for nonconformities in closure. The lot size shall be the number of shipping containers in the end item inspection lot. The inspection level shall be S-2 and the AQL shall be 2.5 nonconformities per hundred units.

<u>Examine</u>	<u>Nonconformities</u>
Markings	Omitted; incorrect; illegible; of improper size, location, sequence, or method of application.
Materials	Any component missing or not as specified. Any component damaged, affecting serviceability.
Workmanship	Inadequate application of components, such as: incomplete closure of container flaps, improper taping, loose strapping, inadequate stapling. Bulged or distorted container.
Contents	Number per container is more or less than required.

4.5 Tests.

4.5.1 Component material testing.

4.5.1.1 Steel composition test. A repeatable consensus standard test method shall be used to verify steel composition as required in 3.2.1.2. Any failure shall fail the lot (see 4.5.1.3).

4.5.1.2 Hardness test. Hardness tests to determine compliance with 3.2.1.3 shall be in accordance with ASTM E 18. Three readings shall be taken at the three blade thickness points indicated on MTDC-1050. During the test, the blade shall be supported to limit the movement and keep the test surface perpendicular to the axis of the penetrator. Any reading not within specified requirements shall constitute a nonconformity.

4.5.1.3 Steel testing documentation. To meet the requirements of 4.5.1.1, a test report/analysis from the steel manufacturer shall be acceptable in lieu of lot by lot testing when validated by the contractor's own tests on the first lot of steel received. The contractor need not retest again unless a new steel supplier is used. To meet the requirements of 4.5.1.2, lot by lot hardness testing may be performed any time after heads are heat treated. A certificate of conformance shall be acceptable when supplied with test data. Hardness testing need not be repeated as part of end item testing.

4.5.2 End item testing. Unless otherwise specified, the sample size for testing shall be S-2 with an AQL of 4.0 for all testing.

4.5.2.1 Handle moisture content testing. Moisture content testing to meet the requirements of 3.2.2.2 shall be part of quality conformance inspection. Moisture testing shall be performed in the following manner: Using a calibrated moisture meter, readings shall be obtained from each end of the handle and its mid point. The handle's moisture content will then be determined by averaging the three readings.

5100-326D

4.5.2.2 Strength test. Strength testing to determine compliance with 3.2.6 shall be performed. One method is shown in figure 1, however, any repeatable method that performs the same function is acceptable. The blade shall be securely clamped and a measurement made of the vertical distance "D" before applying the load. A 175 +1 -0 pound force shall then be applied to the handle at point A, 14-16 inches from the handle end of the tool, in a direction perpendicular to the plane of the blade, for not less than 120 nor more than 125 seconds. The weight shall then be removed and the vertical distance "D" re-measured. The difference in measurement "D" before and after the weight application is the amount of set or bend. Failure is deemed to have occurred if any part of the shovel fractures or breaks or when the permanent set or bend exceeds 1 inch.

4.5.2.2.1 Alternate strength test. As an alternative to the test as shown by figure 1, any test facility that allows accurate repeatable testing, holds the tool in a similar manner, applies the force in the specified places, and can accurately apply the specified force for the specified time is acceptable.

5. PACKAGING

5.1 Preservation. A Shovel Tool Sheath (NSN 8465-01-136-4719) shall be properly applied to each Shovel. The sheath shall be purchased from Committee for the Blind and Severely Handicapped at pricing not to exceed that posted at JWOD.com (see 6.4 for source). All other preservation shall be in accordance with ASTM D3951.

5.2. Packaging. Five shovels shall be placed together and the handles either taped or tied firmly together in two places with either a filament tape or a sisal rope of not less than 200 pounds tensile strength for either tape or rope (see figure 2).

5.3 Packing. Two packages of 5 shovels (10 shovels) prepared as specified in 5.2 shall be packed in each shipping container. All packaging shall comply with the Uniform Freight Classification and the National Motor Freight Classification. Boxes shall be type CF, class Domestic, variety DW, grade 500, style FTC of ASTM D 5118. Inside dimensions 13" wide x 10" deep x 51-1/2" long (see figure 2). Tolerances on all dimensions are -1/2 inch, +1 inch. Metal staples shall be used on all corners and joints. The boxes shall have the flaps outside the side panels of the body and inside the end panels of the cover. When set up, the flaps of the cover shall not overlap, but shall have sufficient length to be securely fastened to the adjoining walls with no less than five staples.

5.4. Marking.

5.4.1 Marking of individual shovels. In addition to the "FSS" and manufacturer markings required by 5100-326B, each shovel shall be marked with "NSN 5120-00-965-0609 NFES 0171." This marking may be placed on the handle or on the blade and may be by any readable method.

5.4.2 Marking of intermediate packaging and shipping containers. Intermediate packages and shipping containers shall be marked in accordance with FED-STD-123. Shipments to the Department of Defense (DoD) shall be marked in accordance with MIL-STD-129.

5.4.3 Special marking. The National Fire Equipment System (NFES) number appearing below the National Stock Number (NSN) of this Item Purchase Description shall be marked on the shipping container below the NSN. The NFES number shall be preceded by "NFES".

6. NOTES

6.1 Intended use. This shovel is intended to be used to cut small limbs and light brush, dig out burning material, throw soil on flaming fuel, and to scrape combustible material down to mineral soil in prescribed burn and wildland fire fighting operations.

6.2 Acquisition requirements. Acquisition documents should specify the following:

- (a) Title, number, and date of this specification.
- (b) When a first article sample is not required (see 3.1, 4.3, and 6.3).
- (c) When lot by lot testing is required in lieu of certificates of compliance (see 4.3.2).
- (d) Preservation, packing, and marking required in addition to specification requirements (see section 5).

6.3 First article. When a first article is required, it shall be inspected and approved under the appropriate provisions of Federal Acquisition Regulation (FAR) 52.209. The first article shall be a preproduction sample. The contracting officer should specify the appropriate type of first article and the number of units to be furnished. The contracting officer should also include specific instructions in acquisition documents regarding arrangements for selection, inspection, and approval of the first article.

6.4 Sheath Source. Plastic sheaths to be installed on the tools must be purchased from Committee for the Blind and Severely Handicapped at the location shown below at pricing not to exceed that posted at JWOD.com.

NISH
Development Workshop, Inc.
555 West 25th Street
Idaho Falls, ID 83402
208-524-1550, FAX 208-523-3148"

6.5 Preparing activity. USDA Forest Service, Missoula Technology and Development Center, 5785 Highway 10 West, Missoula, MT 59808.

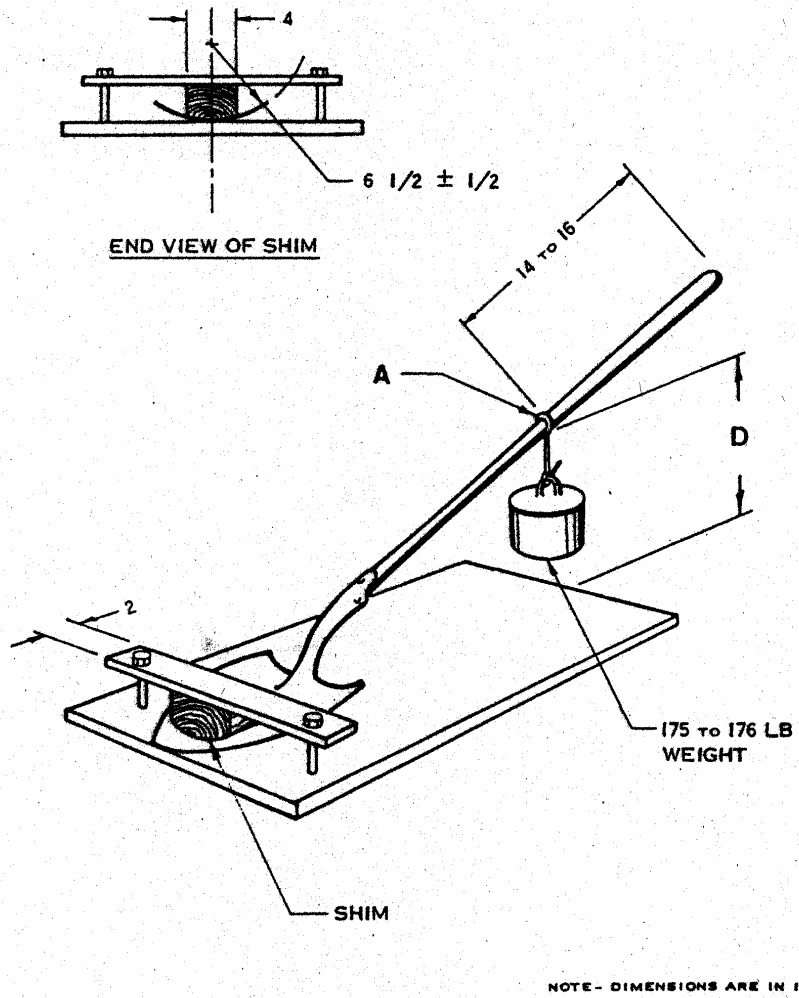

Figure 1.-Method of applying test load.

98-27

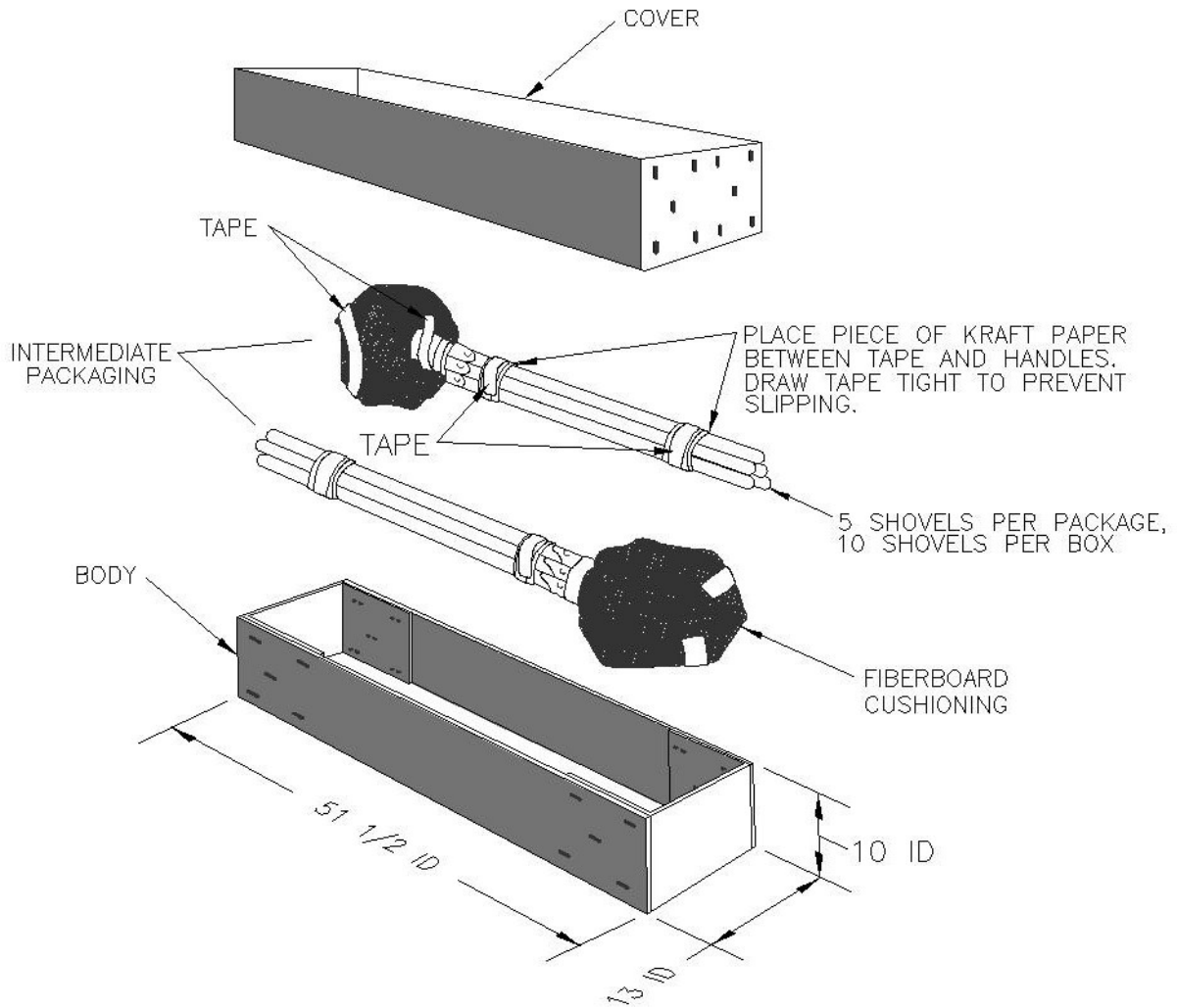

FIGURE 2.-Securing and packaging.



Standardization Document Improvement Proposal

This form is provided to solicit beneficial comments that may improve this document and enhance its use. Contractors, government activities, manufacturers, vendors, and users are invited to submit comments to:

USDA Forest Service
Missoula Technology and Development Center
5785 Highway 10 West
Missoula, MT 59808

Attach any additional pertinent information that may be of use in improving this document to this form and mail in a envelope. A response will be provided when the submitter includes their name and address.

NOTE: This form shall not be used to submit requests for waivers, deviations, or clarification of specification requirements on current contracts. Comments submitted on this form do not constitute or imply authorization to waive any portion of the document, or to amend contractual requirements.

Document Identification: **5100-326D - Shovel, Forest Fire**

Submitter's Name (Optional. Please print or type): _____ Submitter's Organization and Address: _____

Vendor User Manufacturer _____

Phone Number: _____

Date: _____

Has any part of the Document created problems or required interpretation in procurement use?

Is any part of the Document too rigid, restrictive, loose, or ambiguous? Please explain below:

Give paragraph number and wording: _____

Recommended change(s): _____

Reason for recommended change(s): _____

Remarks:

Fold

Attach
stamp

USDA Forest Service
Specifications and Standards
Missoula Technology and Development Center
5785 Highway 10 West
Missoula, MT 59808

Fold and staple for mailing