

UNITED STATES DEPARTMENT OF AGRICULTURE
FOREST SERVICE
SPECIFICATION FOR
3,000-POUND LEADLINES, EXTERNAL, HELICOPTER

1. GENERAL.

1.1. Purpose and Scope. The helicopter leadlines covered in this specification are established as standard in the USDA Forest Service. These external leadlines are used to attach external loads to the cargo hook of a helicopter and are used in activities for the suppression of wildland fire. There are three weight classes of helicopters: light, medium, and heavy. The external leadlines covered by this specification are for use with light and medium helicopters only. The leadlines covered in this specification are for cargo use only. Do not use this specification for any person-lifting application, i.e., short haul.

2. APPLICABLE DOCUMENTS.

2.1. Publications. The following publications of the issue in effect on the date of invitation for bids, form a part of this specification to the extent specified herein.

American National Standards Institute, Inc (ANSI)/American Society for Quality Control (ASQC)

Z 1.4 - Sampling Procedures and Tables for Inspection by Attributes (American Society for Quality Control)

Copies of the ANSI publications can be obtained by writing to the American National Standards, Inc., 25 West 43rd Street, 4th Floor, New York, New York, 10036

Or from their Web site at www.ansi.org.

2.2. Order of Precedence. In the event of conflict between the text of this document and the references cited herein, the text of this document takes precedence. Nothing in this document, however, supersedes applicable laws and regulations unless a specific exemption is obtained.

Beneficial comments, recommendations, additions, deletions, and any pertinent data that may be used in improving this document should be addressed to: USDA Forest Service, San Dimas Technology and Development Center, 444 East Bonita Avenue, San Dimas, CA 91773-3103 by using the Standardization Document Improvement Proposal at the end of this document or by letter.

3. REQUIREMENTS.

3.1. Acceptance. Lot acceptance of like articles shall be performed on product sample(s) in accordance with paragraph 4.4.1.

3.1.1. First Article. Unless otherwise specified, first article inspection shall be performed on a product sample(s) in accordance with paragraph 4.4.2.

3.2. Performance. The leadline shall be capable of performing as specified throughout the temperature range of 0 °F to 140 °F. The leadline shall have a safe working load of 3,000 pounds. The leadline shall have an ultimate strength of at least 11,250 pounds, which corresponds to a 3.75 load safety factor.

3.2.1. Proof Testing. Proof testing of the completed item is required for each and every article in the lot that is being offered for acceptance. The proof test load shall be 6,000 lbs. The manufacturer shall mark the item after proof loading in accordance with paragraph 3.5. Testing and marking shall be performed prior to submittal to the government for first article and acceptance.

3.3. Parts and Materials.

3.3.1. Component Parts. All component parts (including metallic and nonmetallic parts) shall be new and not reprocessed or reworked. When modification is required of commercially available or standard parts, evidence of engineering data or laboratory tests shall be supplied to verify that the modified part meets the requirements of this specification. Each component shall be appropriate for its intended function considering the nature and adverse conditions involved in helicopter operations, including fire fighting (see paragraph 6.1).

3.3.2. Materials. All metallic parts used shall be corrosion resistant or treated for corrosion resistance.

3.3.3. Leadline Material. Leadline material shall be flexible steel wire rope of a minimum diameter of 5/16 inch, maximum diameter of 5/8 inch, and sufficient strength to meet the ultimate strength requirement of 3.2. The contractor shall obtain and retain a certificate(s) of conformance (see paragraph 3.6.) for the leadline material used in this specification.

3.3.3.1. Plastic Coating. Unless otherwise stated in the procuring document, the wire rope shall be plastic coated. The coating shall be 1/32-inch minimum thickness, polyvinyl chloride, ultraviolet-stabilized plastic. The coating shall be transparent to the extent that inspection of the cable under the coating is visually possible. The color of the plastic shall be green or blue, or as specified by the procuring agency.

3.4. Construction and Workmanship. The leadline shall consist of a cable, with a hook (see paragraph 3.7) on one end, and a link (see paragraph 3.8) on the other end as shown in figure 5. The leadline shall be manufactured by current standard production processes to provide a clean, finished, and quality product. Workmanship shall be equal to the best commercial practices consistent with the highest engineering standards in the industry and shall be free from any defect that may impair serviceability or detract from the appearance of the product. The leadline shall be free of sharp edges or other that could result in injury.

3.5. Product Marking. Each and every item procured under this specification shall be marked with a tag showing the item's safe working load in pounds; proof test date (month and year); manufacturer name or trademark; and date (month and year) of manufacture.

The text size shall be a minimum 0.12 inches. The text shall be legibly and permanently stamped, embossed, cut, or etched on to metal tag. The tag shall be either stainless steel or brass. The tag shall be attached to the leadline at the hook end using a galvanized steel wire rope. The securing wire rope for the tag shall be $\frac{1}{16}$ -inch galvanize steel. This wire rope shall be included in the swaging which attaches the hook. The loop formed shall be between 1 and $1\frac{1}{2}$ inches in diameter and oriented in the swage in the direction shown in figure 1.

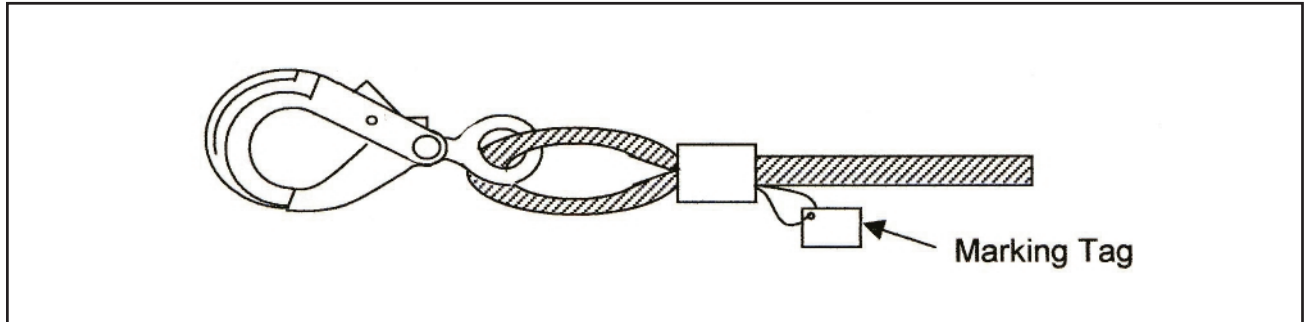

Figure 1—Marking tag

3.6. Certificate of Conformance. Where certificates of conformance are required, the Government reserves the right to verify by test any such item to determine the validity of the certification.

3.6.1. Certification. The contractor shall provide individual certificates of conformance for the component where required in this specification. The contractor shall provide the following information on the certificate:

- a. Item description, i.e., eyelet hook, pear link, thimble
- b. Item manufacturer's name, address, and telephone number
- c. Manufacturer's item part number
- d. Procuring document for the item (to include the quantity and date ordered)
- e. Manufacturer's lot number, if applicable
- f. Manufacturer's statement of safe working load and ultimate strength for the item, or part rating (applicable to thimbles only)

3.7. Hook. The hook used in the leadline shall be an eyelet-style hook only. The hook used in the leadline shall have a safe working load of at least 3,000 pounds and a minimum ultimate strength of 11,250 pounds. The style and dimensions of the hook shall be as shown in figure 2. The contractor shall obtain and retain a certificate(s) of conformance (see paragraph 3.6) for all the hooks installed on leadlines meeting this specification. The hook shall be swaged onto the leadline.

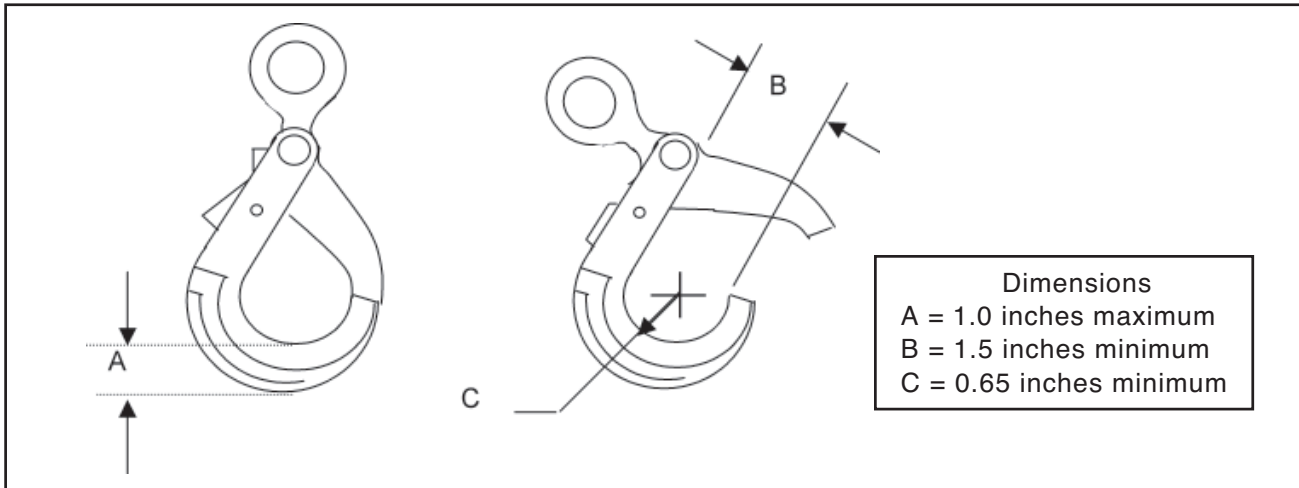

Figure 2—Eyelet hook.

3.7.1. Gate Release. A gate release shall be incorporated in the hook and have a spring return to lock the gate closed. The release lock and hook gate shall have a minimum engagement of 0.130 inches, as shown in figure 3. (Note: The dashed lines in figure 3 are hidden lines.)

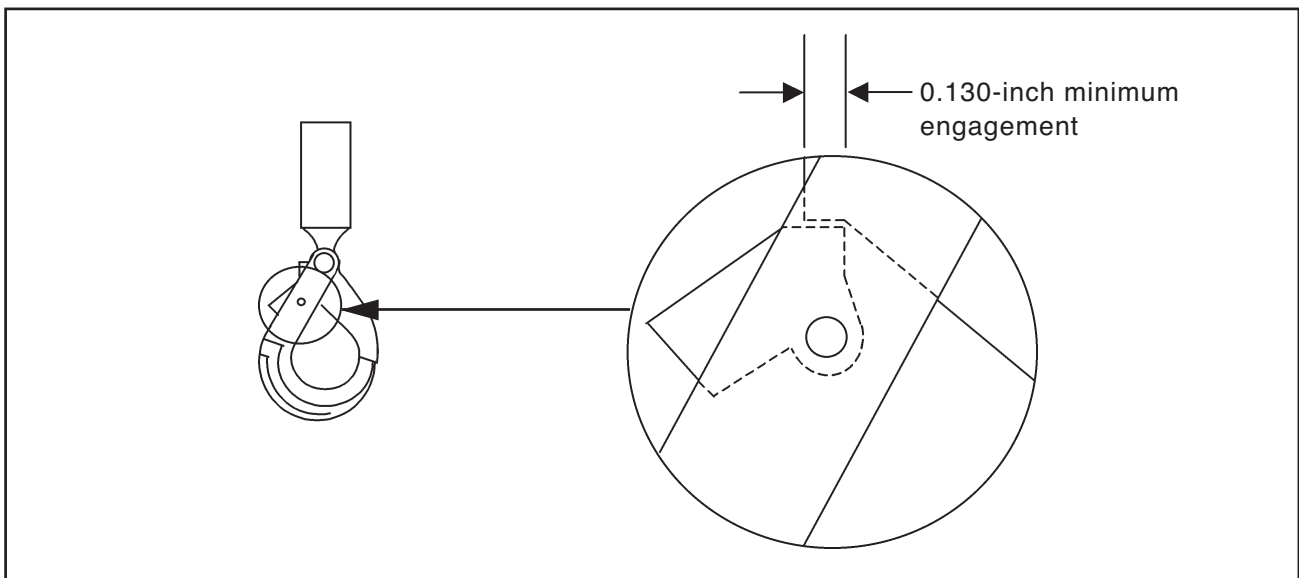

Figure 3—Gate lock engagement.

3.8. Link. The link used in the leadline shall be circular or pear shaped. The link used in the leadline shall have a minimum safe working load of 3,000 pounds and a minimum ultimate strength of 11,250 pounds. The contractor shall obtain and retain a certificate(s) of conformance for all the links presented on leadlines meeting this specification. The dimensions of the link shall be in accordance with figure 4.

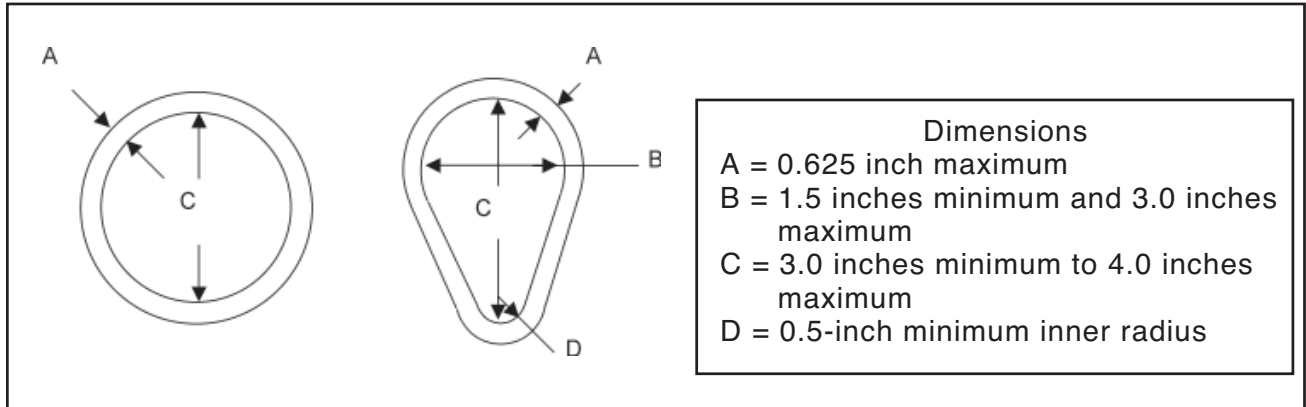

Figure 4—Link dimensions.

3.9. Leadline Length. The ordering activity may specify the lengths of 12 feet, 25 feet, or 50 feet. The tolerance on all lengths shall be +/- 3 inches. The length as shown in figure 5 shall be measured from center to center of the thimbles, with the leadline taut, in a straight line, and on a flat surface.

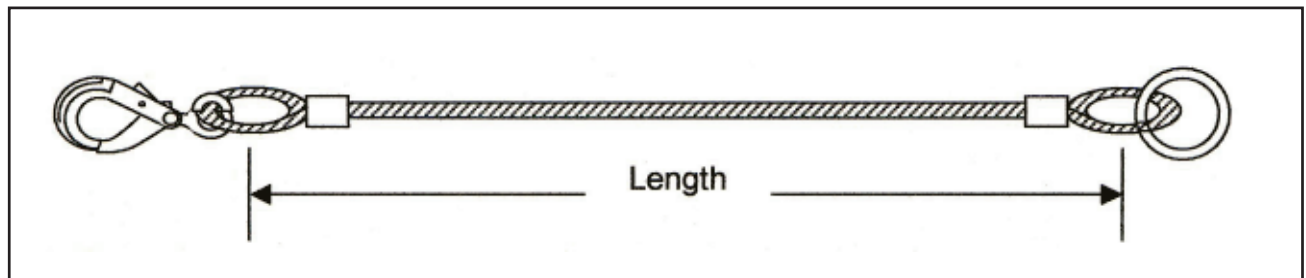

Figure 5—Leadline length.

3.10. Terminations and Splices. Each end of the cable shall be terminated using a thimble. The thimble shall be rated extra heavy or heavy duty. The contractor shall obtain and retain a certificate(s) of conformance for all the thimbles presented on leadlines meeting this specification. The terminations shall incorporate a swage. The swage shall be either stainless or carbon steel, or copper. Aluminum swages shall not be used. The wire rope shall be striped of the plastic coating before swaging. The swaged area shall not incorporate any part of the plastic coating. All swages shall be painted for slip indication as shown in figure 6. The paint color shall be red. The hook end swage shall also be similarly painted. Swages shall not be covered. No splices shall be allowed in the cable. Both terminated ends of the cable shall be fully contained within their swages and the end of the wire rope shall be flush with the swage collar or extend no more than 0.125 inches beyond the swage. In no case shall the end of the cable be contained within the swage.

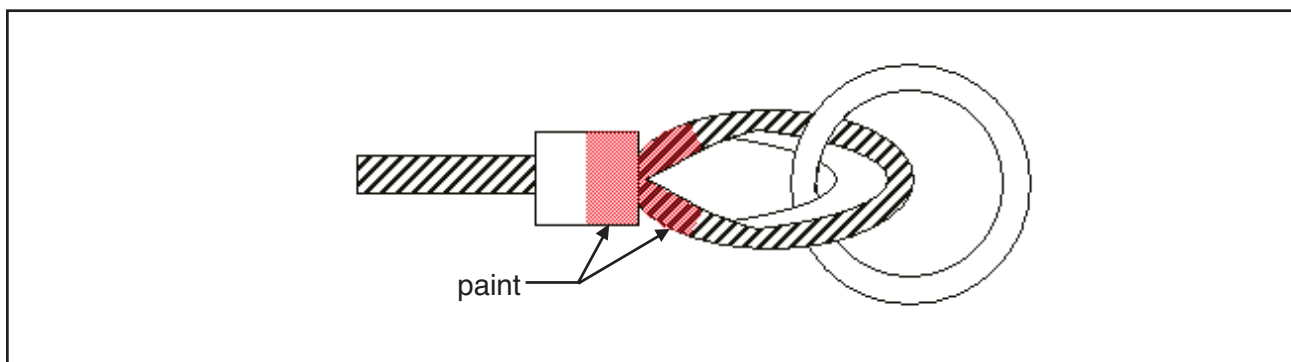

Figure 6—Slip indicator paint.

4. SAMPLING, INSPECTION AND TEST PROCEDURES.

4.1. General Inspections and Tests. The contractor shall be responsible for delivering quality products that meet the requirements of this specification. The contractor shall perform of all inspection and test requirements prior to submission for Government acceptance and tests. The contractor may utilize his or her own test facilities or any commercial laboratory acceptable to the Government. Inspection records of the examination and tests shall be kept complete and available to the Government.

4.2. Responsibility for Compliance. The contractor's inspection system shall assure that all product submitted to the government shall meet all requirements of section 3 and 5. The inspections set forth in this specification shall become a part of the contractor's overall inspection system and quality program. The absence of any inspection requirements in this specification shall not relieve the contractor of the responsibility of the contract. Sampling inspection, as part of manufacturing operations, is an acceptable practice to ascertain conformance to requirements. However, this does not authorize submission of known defective material, either indicated or actual, nor does it commit the Government to accept defective material.

4.3. Sampling for Inspection. When inspection is performed, sampling shall be in accordance with ANSI/ASQC Z 1.4.

4.3.1. Lot. All like items presented together in one delivery will be considered one lot for the purposes of inspections.

4.3.2. First Article. The contractor shall make available to the Government items from which a first article(s) may be selected. The government may select 1, 2, or 3 articles for inspection based on the number of items in the lot.

4.3.3. Sample for Lot Acceptance Inspection/Tests. Sampling for lot acceptance shall be in accordance with ANSI/ASQC Z1.4. The sample size shall be per special inspection level S-3.

4.4. Inspection and Tests.

4.4.1. Lot Acceptance. When selected in accordance with 4.3.3, each sample item shall be inspected in accordance with table 1, to determine conformance with this specification. If the sample is found to have any major nonconformances, as identified in table 1, the lot shall not be accepted. Additionally, if the number of minor nonconformances (per table 1) in the sample exceeds an AQL level of 1.5 percent nonconforming, the lot shall not be accepted.

Table 1—Lot acceptance inspection

Reference Paragraph Number	Nonconformance	Class of Nonconformance
3.2.1.	The leadline was not a proof tested.	Major
3.3.2.	All exposed metal parts are not corrosion resistant or treated for corrosion resistance.	Major
3.3.3.	The wire rope used in the leadline has a smaller diameter than 5/16 inches.	Major
3.3.3.1.	The wire rope is not plastic coated.	Major
3.3.3.1	The plastic coating is not transparent.	Major
3.3.3.1	The plastic coating is not either green or blue.	Major
3.4.	The leadline does not consist of a steel cable with a link at one end and a hook at the other.	Major
3.4.	The leadline contains sharp edges, burrs, or other that could result in injury.	Major
3.4.	The workmanship of the leadline is below industry standards.	Minor
3.5.	Marking does not contain all of the required information.	Major
3.5.	Test is not at least 0.12 inches in height.	Major
3.5.	Any lettering is not legible.	Major
3.5.	Text is not embossed, stamped, cut or etched into a stainless steel or brass tag.	Major
3.5.	The tag is not located at the hook end.	Major
3.5.	The wire rope attaching the tag to the leadline is not included in the swage of the cable termination.	Major
3.5.	The tag is not oriented in the swage as shown in figure 1.	Major
3.7.	Any dimension of the hook is not per figure 2.	Major
3.7.1.	The minimum engagement of the gate and lock release is not greater than shown in figure 3.	Major
3.8.	The link is not either a round or pear-shaped link.	Major
3.8.	The link does not meet the dimensions shown in figure 4.	Major
3.9.	The length of the leadline is not as required by the procuring document, measured as shown in figure 5.	Major
3.10.	The leadline termination does not include a thimble, and the thimble is not heavy duty or extra heavy.	Major
3.10.	The swages used are not either stainless or carbon steel, or copper.	Major
3.10.	The swaged area incorporates the any part of the plastic coating.	Major
3.10.	The swages are not painted for slip indication.	Major
3.10.	The leadline includes a splice.	Major
3.10.	The cut end of the wire rope for either termination does not extend beyond the swage collar.	Major
3.10.	The cut end of the wire rope for either termination extends more than 0.125 inches beyond the swage.	Major

4.4.2. First Article Inspection. Unless otherwise specified in paragraph 6.4, the first article(s) submitted in accordance with paragraph 3.1.1, shall be inspected as specified in paragraph 4.4.1 and table 2. The sample size shall be in accordance with paragraph 4.3.2. Government inspection of compliance on the first article(s) may stop upon any single failure (regardless of classification), and the sample(s) rejected. The contractor will be informed of the nature of the failure. Additionally, the Government is not be obligated to continue with first article compliance inspection, unless it is considered in the best interest of the Government.

Table 2—First article inspections

Reference Paragraph Number	Nonconformance	Class of Nonconformance
3.2.	The leadline assembly does not have an ultimate strength of at least 11,250 pounds.	Major
3.3.1.	All of the components are not new, and engineering/test data have not been provided justifying the use of reworked/modified component(s).	Major
3.3.1.	Each component is not appropriate when considering its intended function.	Major
3.3.3.	A certificate of conformance for the leadline material containing all of the required data was not provided.	Major
3.7.	A certificate of conformance for the hook containing all of the required data was not provided.	Major
3.8.	A certificate of conformance for the link containing all of the required data was not provided.	Major
3.12.	The swivel does not freely rotate up to the safe working load.	Major
3.13.	Sharp edges and points exist in the swivel design.	Major

4.4.2.1. First Article Inspection Package. The contractor shall submit to the Government along with the selected first article(s), copies of:

- a. Engineering analysis or test data for altered commercial products, if applicable, paragraph 3.3.1
- b. All Certificates of Conformance, see 3.6, 3.7, 3.8, and 3.10
- c. Company Inspection Records, paragraph 4.1
- d. All Test Results for the article(s), paragraph 4.7
- e. Ultimate Strength Certificate, paragraph 4.6
- f. Calibration/metrology information on test equipment that was used as a media of inspection, paragraph 4.7
- g. All other material necessary to perform the inspections identified in table 2

4.5. Proof Testing. Proof testing shall place the item under the load specified for the item in paragraph 3.2.1. The applied force shall be a static load applied in the direction the item will encounter in its intended use. The equipment used to apply the loading force shall be calibrated to a recognized State or Federal standard. The calibration of the equipment shall be current at the time of testing.

4.5.1. Proof Testing Inspection. All items shall not exhibit any plastic deformation, take a permanent set, or change its dimensional properties as a result of the proof-test load.

4.6. Ultimate Strength Testing. The contractor shall perform testing to verify the completed leadline ultimate strength. Testing shall place the item under the load specified for the item in paragraph 3.2 and held for 10 seconds. The applied force shall be a static load applied in the direction the item will encounter in its intended use. The equipment used to apply the loading force shall be calibrated to a recognized State or Federal standard. The calibration of the equipment shall be current at the time of testing.

4.6.1. Ultimate Testing Inspection. The item shall not fail, break, or release the load. The item may yield, experience plastic deformation, or change its dimensional properties as a result of the ultimate test load, but shall not fail or break. All items subjected to ultimate testing shall be considered consumed by the testing. As such, they shall not be delivered to government stock or supply.

4.6.2. Certification of Ultimate Test Result. The contractor shall prepare and provide as part of the first article inspection and upon request of any Government inspector, a certificate of conformance for the ultimate strength test. The certificate shall contain the following:

- a. Product description
- b. Description of the test equipment involved and the metrology information
- c. Manufacturer's name, address, and telephone number
- d. Manufacturer's lot number
- e. Product's date of manufacture
- f. Test company name, address, and telephone number
- g. Testing date
- h. Test technician's name and title
- i. All characteristic test values, paragraph 4.7

4.7. Test Results. The contractor shall have available copies of all test results performed to assure the quality or acceptability of the product submitted for acceptance. The test results shall also show the product's acceptable range or expected test result and the item's test value. All test equipment, which shall be used as media of inspection, shall be calibrated and current at the time of testing. Calibration shall be to a recognized State or Federal standard. The company shall obtain and retain calibration information on all equipment that is used as a media of inspection for items delivered under this specification.

4.8. Nonaccepted Lots. Nonaccepted lots may be offered again for inspection in accordance with paragraph 6.4 of ANSI/ASQC Z1.4, except that Table 2-B – Single sampling plans for tightened inspection (Master table) from ANSI/ASQC A1.4 shall be used with the parameters of paragraph 4.4.1.

4.9. Government Lot Acceptance. The Government will conduct lot acceptance inspections and tests to determine compliance with the specification. The Government's inspection will be in accordance with the requirements of section 4. If lot acceptance and tests are conducted at locations other than the manufacturing facilities, the contracting officer will specify location and arrangements. In the case of onsite inspections at the contractor facility, the contractor shall furnish the inspector all reasonable facilities for their work. During any inspection, the inspector may take from the lot one or more samples and submit them to an independent test laboratory approved by the Government or to a Government test facility for inspection and tests.

5. PACKAGING, PACKING AND CONTAINER/SHIPMENT MARKING.

5.1. Packaging, Packing and Container/Shipment Marking. The packaging, packing, and container/shipment marking shall be as specified in the contract or order.

6. NOTES.

6.1. Intended Use. All items procured under this specification are intended to attach external loads to the cargo hook of a helicopter and used in the suppression of wildland fire or related activities. The wildland fire environment includes, but is not limited to, fire retardants; dust; moisture; fuels (aviation, jet, gasoline, kerosene, diesel, etc.); hydraulic fluid and oils (aviation and automotive); herbicides; pesticides; and lubricants (aviation and automotive).

6.2. Acquisition Requirements. Acquisition documents should specify the following:

- a. Title, number, and date of this specification.
- b. If a first article sampling and inspection is not required (see paragraphs 3.1.1, 4.4.2, and 6.4).
- c. Whether plastic coating is required on leadlines and color (see paragraphs 3.3.3.1).
- d. The required length of leadlines (see paragraph 3.9).
- e. Packaging and packing and marking (see paragraph 5.1).

6.3. Metric Equivalence. The following table provides the conversion factors to be used in creating metric equivalence for this specification.

Conversion Factors		
English System	Calculation	To Obtain Metric Equivalence
Pounds	lbs. * 0.453	Kilograms
Inches	in. * 2.54	Centimeter
Inches	in. * 25.4	Millimeters
Foot	ft * 0.305	Meter
Fahrenheit	(° F-32)*(5/9)	Centigrade

6.4. First Article. When a first article sample(s) is required, it shall be inspected and approved in accordance with the first article clauses set forth in the solicitation. Specific instructions shall be included regarding arrangements for selection, inspection and approval of the first article sample(s). The first articles shall be subjected to the ultimate strength requirement of paragraph 3.2. As such, the first articles will be consumed in test. Hence, they shall not be delivered to Government stock or supply.

6.5. Superseding Data. This document supersedes 5100-500e for leadlines only.

6.6. NOTICE. When Government drawings, specification and standards or other data are used for any purpose other than in connection with a definitely related Government procurement operation, the United States Government thereby incurs no responsibility nor any obligation whatsoever.

6.7. Preparing Activity. USDA Forest Service, Technology & Development Center, 444 East Bonita Avenue, San Dimas, CA 91773-3103.

**United States Department of Agriculture, Forest Service
Standardization Document Improvement Proposal**

Instructions: This form is provided to solicit beneficial comments that may improve this document and enhance its use. Contractors, government activities, manufacturers, vendors, or other prospective users of this document are invited to submit comments to the USDA Forest Service, San Dimas Technology and Development Center, 444 East Bonita Avenue, San Dimas, California 91773-3103. Attach any pertinent data that may be of use in improving this document. If there is additional documentation, attach it to the form and place both in an envelope addressed to the preparing activity. A response will be provided when a name and address are included.

Note: This form shall not be used to submit request for waivers, deviation, or for clarification of requirements on current contracts. Comments submitted on this form do not constitute or imply authorization to waive any portion of the referenced document(s) or to amend contractual requirements.

Standard Number and Title: **Specification 5100-503, 3,000 Pound Swivel Hook, External, Helicopter**

Name of Organization and Address:

___ Vendor ___ User ___ Manufacturer

1. ___ Has any part of this document created problems or required interpretation in procurement use?

2. ___ Is any part of this document too rigid, restrictive, loose, or ambiguous?
Please explain below.

Give paragraph number and wording:

Recommended change (s):

Reason for recommended change (s):

Remarks:

Submitted by: (Print or type name and address - Optional)

Telephone number:
(Optional)

Date:

USDA Forest Service
San Dimas Technology & Development Center
Attn: Specification and Standards Project Leader
444 East Bonita Avenue
San Dimas, California 91773-3103

Fold and staple for mailing